



CT1

“Series 2”

General Purpose Timer

Installation Manual 1st Edition

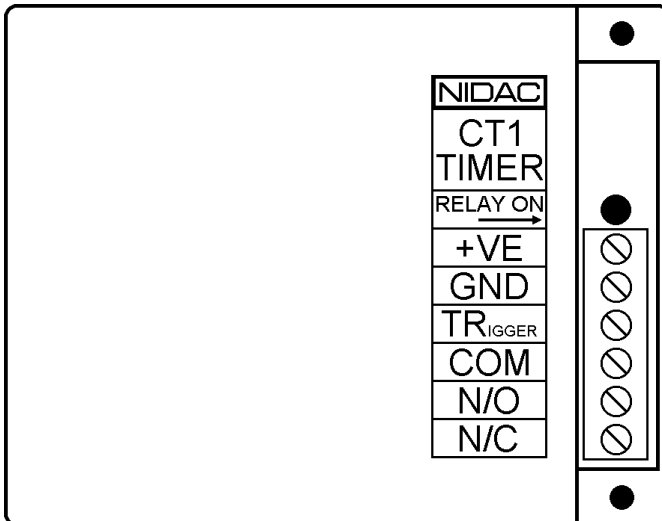

FEATURES

- 4 Timing Ranges:
 - 1 to 127 seconds in 1 second increments.
 - 10 seconds to 21 minutes in 10 second increments.
 - 1 to 127 minutes in 1 minute increments.
 - 10 minutes to 21 hours in 10 minute increments.
- Accurate DIP switch selection (no pots).
- Selectable Positive, Negative or Dual Edge trigger.
- 7 operating modes:
 - Normal timer.
 - Pulse (trigger) Extension.
 - Dual edge.
 - Delay on.
 - Delay on retriggerable.
 - Normal timer retriggerable.
 - Bistable (clutch) operation.
- Heavy duty 5 amp. change over relay.
- Fail Safe or Fail Secure relay operation.
- LED indication of relay operation.
- 12 volt D.C. operation.
- 36 month manufacturers warranty.

SPECIFICATIONS

Operating Voltage:- 12 volts D.C.
Quiescent Current:- 100 mA. @ 12 volts D.C. (180 mA. with relay on).
Trigger Current:- 1 mA. @ 12 volts D.C.

Relay

Maximum Switching Current:- 5 Amps.
Maximum Switching Voltage:- 30 VDC, 125 VAC.

WARNING: DO NOT USE 240V ON THE RELAY CONTACTS!

SETTING UP THE CT1

The CT1 is set up using the 14 Dip Switches located inside the case. To open the case, insert a small flat bladed screwdriver into one of the slots located on either side of the case and gently twist it. Repeat this operation for the opposite side until the lid can be removed.

The red LED above the terminals represents the relay state. When it is ON, the relay is energised.

SETTING THE TIME

Dip switches 1 to 7 are used to set the CT1 timing period. The function of these dip switches is explained below.

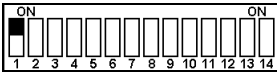

Dip switch 1 ON adds 1 time interval to the time.

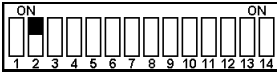

Dip switch 2 ON adds 2 time intervals to the time.

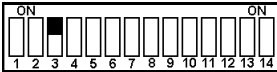

Dip switch 3 ON adds 4 time intervals to the time.

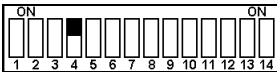

Dip switch 4 ON adds 8 time intervals to the time.

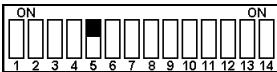

Dip switch 5 ON adds 16 time intervals to the time.



Dip switch 6 ON adds 32 time intervals to the time.



Dip switch 7 ON adds 64 time intervals to the time.

Time Intervals

The time intervals mentioned above are determined by dip switches 8 and 9:



Dip switch 8 & 9 OFF - time interval = 1 second.



Dip switch 8 ON, 9 OFF - time interval = 10 seconds.



Dip switch 8 OFF, 9 ON - time interval = 1 minute.



Dip switch 8 & 9 ON - time interval = 10 minutes.

Time Setting Examples:



Sets the time for 45 seconds ($1 + 4 + 8 + 32 = 45$ seconds).



Sets the time for 3 minutes and 10 seconds
($10 + 20 + 160 = 190$ seconds).



Sets the time for 58 minutes ($2 + 8 + 16 + 32 = 58$ minutes).



Sets the time for 20 hours
($80 + 160 + 320 + 640 = 1200$ minutes).

Bistable Mode: When dip switches 1 to 7 are all OFF the timer is placed in bistable mode. When triggered with the appropriate trigger voltage (see dip switch 10 - Trigger Polarity below) the relay will change state. When triggered again, the relay will change state again.



Sets the CT1 for Bistable Mode.

Note: In bistable mode, no timing function is performed and the two time interval selection switches (dip switches 8 and 9) and the three mode select switches (dip switches 12, 13 and 14) have no effect.

TRIGGER POLARITY

Dip switch 10 is used to select between a positive and negative trigger voltage.

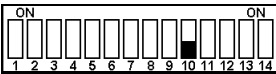

The CT1 is triggered when a positive voltage (5V to 12V D.C.) is applied to the trigger input.

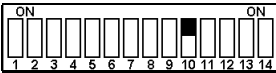

The CT1 is triggered when zero volts is applied to the trigger input.

Note: If Dual Edge mode is selected by using dip switches 12, 13 and 14 and the CT1 is NOT in bistable mode, the CT1 will trigger when the trigger voltage selected above is either applied OR removed.

FAIL SAFE/SECURE

Dip switch 11 is used to select between fail safe and fail secure relay operation. When fail safe mode is selected, the relay is energised (NC contacts open, NO contacts shorted, LED ON) when the timer is not timing and de-energised when timing is started. If power is removed from the CT1, the relay will de-energise (NC contacts shorted, NO contacts open).

When fail secure is selected, the relay is only energised (NC contacts shorted, NO contacts open) when timing has commenced.

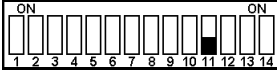

CT1 relay state is Fail Secure.

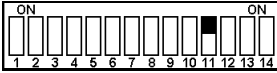

CT1 relay state is Fail Safe.

MODE SELECT SWITCHES

Dip switches 12, 13 and 14 select the operating mode of the CT1.

Note: The mode switch settings are NOT valid when the timer is in bistable mode (dip switches 1 to 7 all OFF).

Normal Timing

In normal timing mode the CT1 turns the relay ON when triggered and turns it OFF after the set time has elapsed. If any further triggers occur while the relay is ON, they are ignored (See Timing Diagram 1).

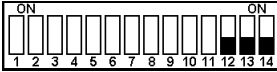

Selects Normal timing.

Pulse Extension

When Pulse Extension is selected and the CT1 is triggered, the relay will turn ON and stay ON while the trigger remains at the trigger voltage (zero volts for a negative trigger, a positive voltage for a positive trigger). When the trigger is removed, the relay remains ON for the time set (See Timing Diagram 1).

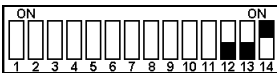

Selects Pulse Extension.

Dual Edge

When the trigger is either applied or removed from the trigger input, the relay will turn ON for the time set. If any further triggers occur while the relay is ON, they are ignored. (See Timing Diagram 3).



Selects Dual Edge

Retriggerable

When triggered the CT1 relay will turn ON and turn OFF after the time set. If another trigger occurs while the relay is ON, timing is restarted and the relay remains ON for the time interval set (See Timing Diagram 2).

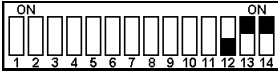

Selects Retriggerable.

Delay On

When triggered in Delay On mode, the CT1 relay will remain OFF for the time set and turn ON for 1 second after the time set has elapsed. If any further triggers occur while the CT1 is timing, they are ignored. (See Timing Diagram 1).

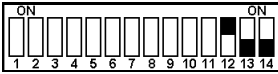

OR

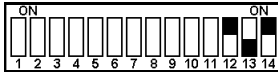

Selects Delay On.

Retriggerable Delay On

When the CT1 is triggered, the relay remains OFF for the time set and turns ON for 1 second if no further triggers occur. If another trigger occurs while the relay is OFF and the delay timing has started, timing is restarted (See Timing Diagram 2).

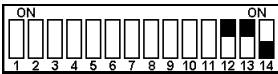

OR

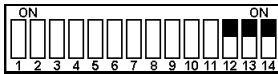

Selects Retriggerable Delay On.

TIMING DIAGRAMS

TIMING DIAGRAM 1

Normal, Pulse Extension and Delay On modes with the trigger input set up for a positive trigger and the relay in fail secure mode.

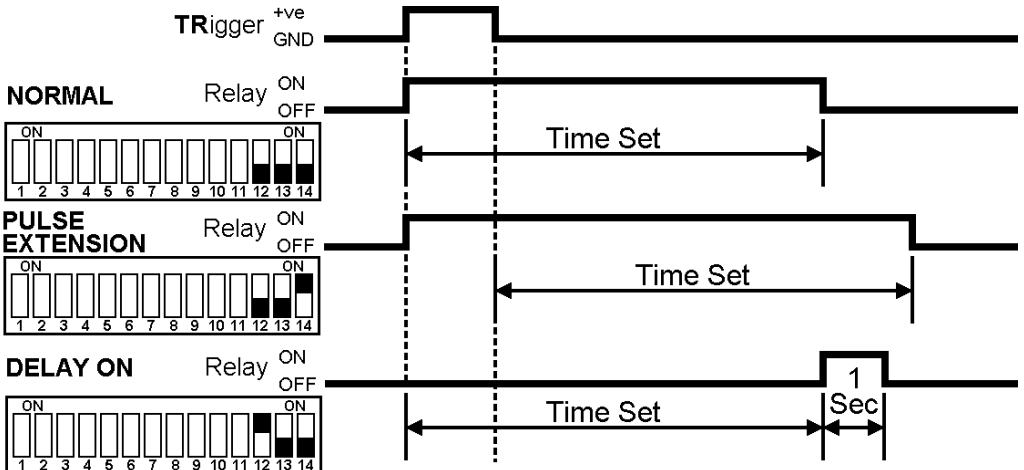

TIMING DIAGRAM 2

Retriggerable and Retriggerable/Delay On modes with the trigger input set up for a positive trigger and the relay in fail secure mode.

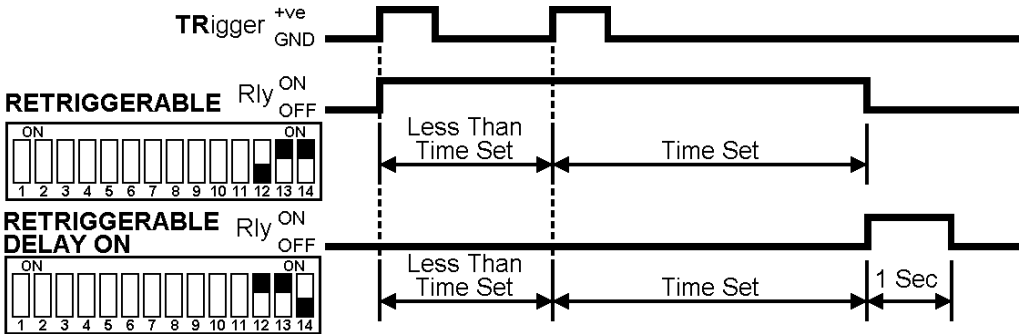

TIMING DIAGRAM 3

Dual Edge mode with the relay in fail secure mode.

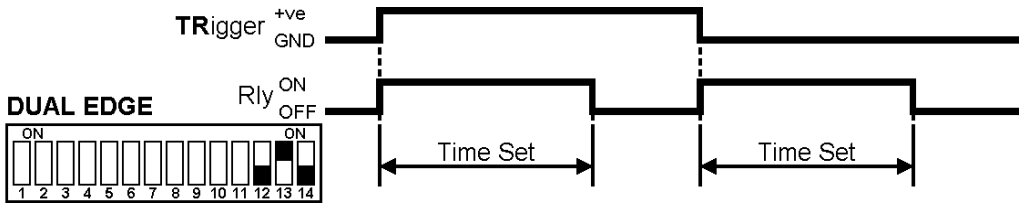



NIDAC

NIDAC SECURITY PTY. LTD.

A.C.N. 004 933 242

MANUFACTURERS OF SECURITY EQUIPMENT

2 CROMWELL STREET

BURWOOD, VICTORIA

TEL: (03) 9808 6244

AUSTRALIA 3125

FAX: (03) 9808 9335