



PIM

Presco™ Interface Module

“Series 2”

Revision B

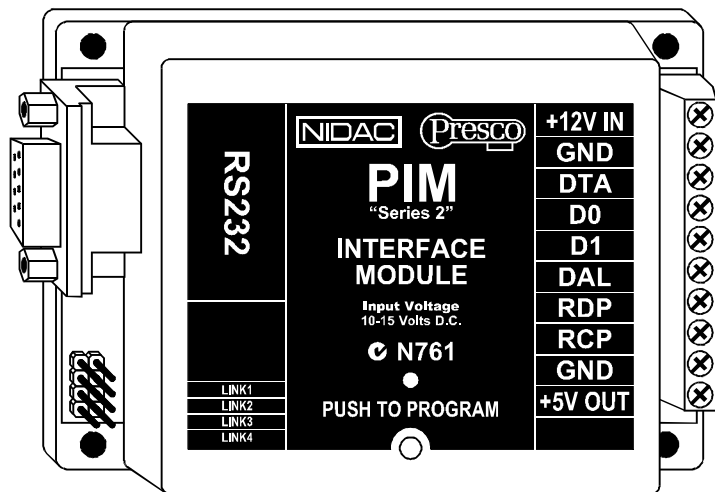

INTRODUCTION

The Presco™ Interface Module (PIM) can be used to convert commonly used data formats to Nidac Presco™, RS232 or Wiegand format data.

FEATURES

- Converts from Wiegand, RS232, Nidac Presco™, Clock & Data (Magnetic Card) or Dallas iButton™ (commonly referred to as Silicon Key) format.
- Converts to Nidac Presco™, RS232 or Wiegand format.
- Can convert to or from Wiegand with up to 64 bits of data, including up to 32 bit site code plus optional start and end parity bits.
- User programmable site code when converting to Wiegand.
- Reads up to 64 bits from Dallas iButton™ user memory or 56 bits from factory ID.
- Reads up to 32 characters or digits from Track 1, 2 or 3 Clock/Data (magnetic card) format input.
- User programmable options using standard Presco™ PRE keypad or via RS232 link (software for RS232 programming is available for ‘ClubWeb’ members from Nidac’s website www.nidac.com or by emailing a request to pim.software@nidac.com).
- Compatible with **all** current Nidac Presco™ encoders and decoders.

1

SPECIFICATIONS

Voltage:	10 to 15 Volts D.C.
Current:	75mA max (plus 5V output draw).
Dimensions:	104mm x 72mm x 27mm.
Weight:	120gms.
Wiegand	Pulse Width: 50µs Pulse Separation: 2ms
RS232:	Baud Rate: 300, 600, 1200, 2400, 4800, 9600, 19200 or 38400 bps. Data bits: 8 Parity: None, Odd or Even. Handshaking: Hardware or None.

TERMINAL DESCRIPTIONS

+12V IN	The positive D.C. power input.
GND	The Ground (or Negative) power input. This is also a common reference connection for all devices connected to the PIM. i.e. all devices connected to the PIM require their GNDs to be connected together.
DTA	Presco™ data input/output.
D0	Wiegand Data 0 input/output.
D1	Wiegand Data 1 input/output.
DAL	Dallas iButton™ input.
RDP	The R ead D ata P ulse input (for Clock/Data).
RCP	The R ead C lock P ulse input (for Clock/Data).
+5V OUT	A 5 Volt D.C. power output for powering connected equipment (100mA. max.).

2

CABLING DISTANCES TO PIM

Device	Cable type	Max length
RS232	7/020 or CAT 5 UTP cable. 4 core (3 wires) required for no handshaking. 6 core (5 wires) required for hardware handshaking.	10m
iButton™	Telephone cable Must be unshielded twisted pair. 2 core for reader only. 4 core for reader + LED control.	10m
iButton™	CAT 5 cable. Use 1 pair for reader, any other wires for LED control.	100m
Clock/Data	7/020 shielded cable. 4 core for reader only. 6 core for reader + LED control. Ground the shield at PIM end only.	100m
Wiegand	7/020 shielded cable. 4 core for reader only. 6 core for reader + LED control. Ground the shield at PIM end only.	100m
Presco™ PRE keypad	7/020 unshielded cable. 2 core (figure 8) for data only, no LED control. 4 core for PRE with LED control.	1000m
Presco™ PSE keypad without backlighting	2 core (figure 8) 7/020 unshielded cable.	1000m

3

Device	Cable type	Max length
Presco™ PSE keypad with backlighting	4 core 7/020 unshielded cable. NOTE decreased distance is due to extra current drawn by backlighting.	500m
Presco™ proximity reader	4 core 14/020 unshielded cable.	1000m
	4 core 7/020 unshielded cable. NOTE decreased distance is due to extra current drawn by powering the reader.	350m 800m

NOTE all distances are based on a supply voltage of 12.0 VDC at the PIM.

SETTINGS SUMMARY

Links	Input	Output
LINK 1 LINK 2 LINK 3 LINK 4	Clock/Data	Presco™ (PDA, KC2 or KC6)
LINK 1 LINK 2 LINK 3 LINK 4	Clock/Data	RS232
LINK 1 LINK 2 LINK 3 LINK 4	Presco™ DLOG (from PAC1/2)	RS232
LINK 1 LINK 2 LINK 3 LINK 4	RS232	Presco™ DLOG (to PACDL)
LINK 1 LINK 2 LINK 3 LINK 4	Dallas iButton™	Presco™ (PDA, KC2 or KC6)
LINK 1 LINK 2 LINK 3 LINK 4	Dallas iButton™	RS232

4

Links	Input	Output
LINK 1 LINK 2 LINK 3 LINK 4	Wiegand	Presco™ (PDA, KC2 or KC6)
LINK 1 LINK 2 LINK 3 LINK 4	Wiegand	RS232
LINK 1 LINK 2 LINK 3 LINK 4	Clock/Data	Presco™ (PAC1 or PAC2)
LINK 1 LINK 2 LINK 3 LINK 4	Clock/Data	Wiegand
LINK 1 LINK 2 LINK 3 LINK 4	RS232	Presco™ (all decoders)
LINK 1 LINK 2 LINK 3 LINK 4	Presco™	RS232
LINK 1 LINK 2 LINK 3 LINK 4	Dallas iButton™	Presco™ (PAC1 or PAC2)
LINK 1 LINK 2 LINK 3 LINK 4	Dallas iButton™	Wiegand
LINK 1 LINK 2 LINK 3 LINK 4	Wiegand	Presco™ (PAC1 or PAC2)
LINK 1 LINK 2 LINK 3 LINK 4	Presco™	Wiegand

IMPORTANT NOTE: The required operational mode of the PIM (as set by the links above) **MUST** be set **BEFORE** applying power to the unit or exiting program mode.

5

Converting from CLOCK/DATA

When reading from a Clock & Data device the PIM accepts Track 1, 2 or 3 format Clock/Data inputs on the RDP and RCP terminals. The CLS signal from the reader is not used.

The PIM reads up to a maximum of 32 characters from the data stream, though the actual maximum is dependant upon the data conversion type.

The characters read are either the starting characters or the ones directly before the first separator or end sentinel character.

Factory default characters to read = 8 (Memory 040)

Factory default data type = Track 2/Track 3 (Memory 041)

Factory default Read from Start or End = End (Memory 042)

Clock/Data to Wiegand

LINK 1 LINK 2 LINK 3 LINK 4	Links 1 & 4 ON
--------------------------------------	----------------

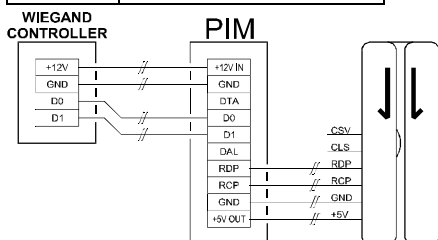

The PIM reads up to 32 characters from the data stream.

If reading from track 1 and a non numeric character is found in the data stream then the PIM will ignore the card.

The data read from the Clock/Data source is converted to a binary number. The bits above the number of bits specified for the Wiegand user code are then discarded.

6

Clock/Data to PRESCO™ for PAC1 or PAC2

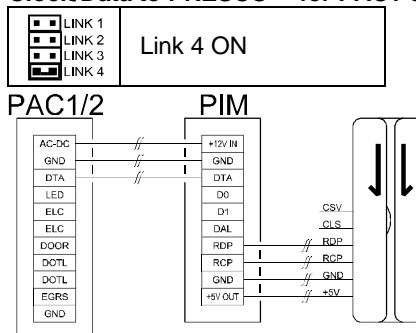

The PIM reads up to nine (9) digits from the data stream.

If reading from track 1 and a non numeric character is found in the data stream then the PIM will ignore the card.

Clock/Data to PRESCO™ for PDA, KC2 or KC6

LINK 1 LINK 2 LINK 3 LINK 4	All Links OFF
--------------------------------------	---------------

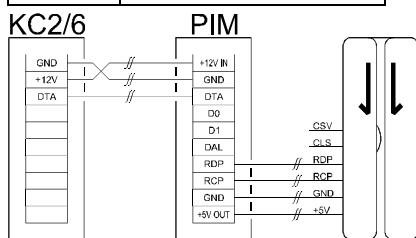

The PIM reads up to seven (7) digits from the data stream.

If reading from track 1 and a non numeric character is found in the data stream then the PIM will ignore the card.

7

Clock/Data to RS232

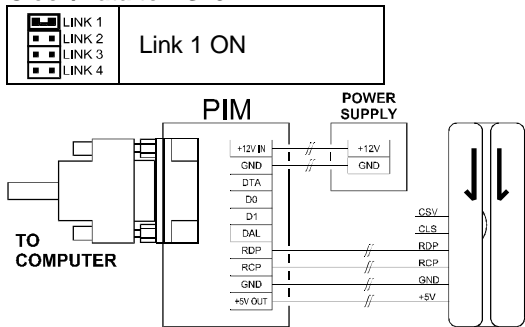

The PIM reads up to 32 characters from the data stream.

Converting from Presco™ DLOG

The information to and from the DLOG terminal on a PAC1 or PAC2 is normally monitored and controlled by the PACDL. This allows for adding, changing and deleting codes and setting options as well as monitoring code and input usage on the PAC1/PAC2.

Presco™ DLOG to RS232

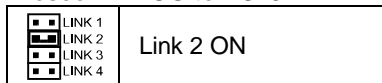

All information is sent unfiltered to and from the RS232 port.

NOTE: It is not recommended that this mode be used unless you have full details about the information sent to and from the DLOG communication I/O. This information is only supplied upon request to those with a reasonable usage.

Presco™ to RS232

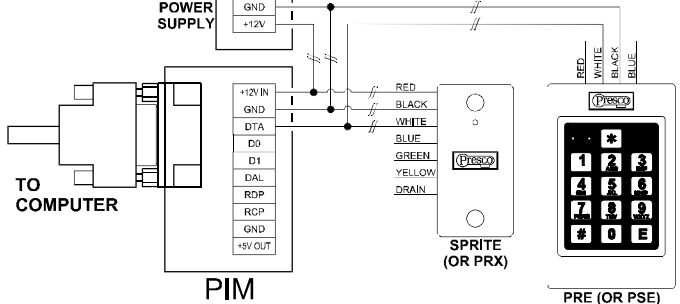
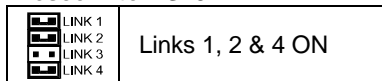

Once the data has been entered at a Presco™ encoder (card presented at reader or code then E pressed on keypad) it will be sent to the RS232 port.

The PIM can then optionally make the encoder respond with a noise as set by the *good return character* in memory 081.

Data sent from to the RS232 port can be either filtered (only the code digits are sent) or unfiltered (preamble characters, code and enter character are sent).

Factory default filter selection = Filter data and automatically send return character to generate an audible response on the encoder (Memory 080)

Converting from Presco™

The PIM can read information from any of the Presco™ encoders, including PRE & PSE keypads and PRX & Sprite Proximity readers.

Presco™ to Wiegand

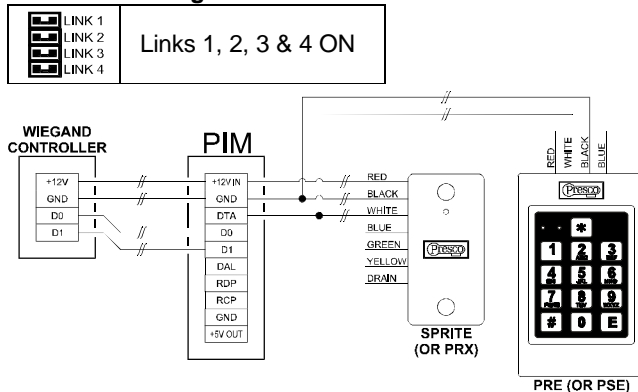

When converting from a keypad the number entered from the keypad is converted to the user code portion of the Wiegand code. If the number entered is larger than that allowed by the number of bits specified for the Wiegand user code then the maximum value for the user code will be sent.

Conversion from a Proximity reader to standard 26 bit Wiegand will produce the same site and user code as if the Wiegand output from the reader had been used. This is useful if wanting to cable a Wiegand system further than 100m from reader to controller. If converting to a Wiegand format other than standard 26 bit, the result is undefined.

The PIM automatically makes the Presco™ device respond with the noise as set in memories 401 and 402 for good and bad inputs (a bad input is when a number too large for the user code is entered from a keypad).

Converting from Dallas iButton™

Either the unique factory ID code or the user memory (selected iButton™s only) can be read.

When reading the factory ID up to 56 bits can be read, 8 bit family code + 48 bit serial number.

Up to 64 bits of user memory can be read.

NOTE: The PIM will not read an iButton™'s memory that contains all 0s or all 1s for the number of bits being read.

Factory default bits to read = 32 (Memory 060)

Factory default data to read = factory ID (Memory 061)

Dallas iButton™ to Wiegand

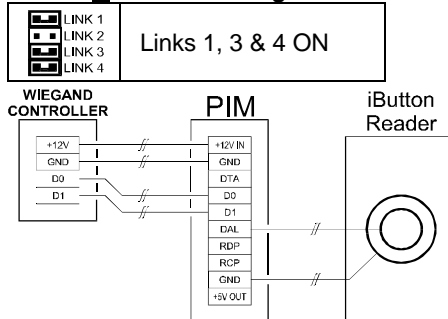

If the number of bits read from the iButton™ is less than the number of bits specified for the Wiegand user code then the user code will be padded with zeroes (0).

If the number of bits read from the iButton™ is more than the number of bits specified for the Wiegand user code then the extra bits will be ignored and only the lower bits will be sent as the Wiegand user code.

Dallas iButton™ to PRESCO™ for PAC1 or PAC2

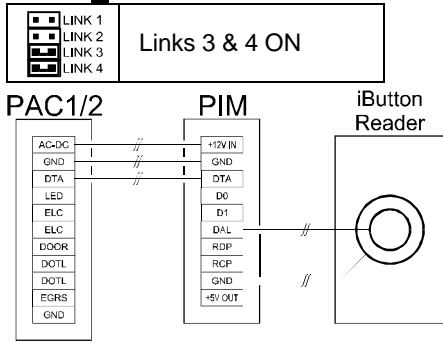

The PIM reads the number of bits specified and converts them to either a decimal or base 12 number. The lowest 9 digits of this number are sent as the code.

The conversion type (decimal or base 12) can be selected via memory 065.

Note: PIM series 1 converted 32 bits to base 12.

Factory default conversion type = Base 12 (Memory 065)

Dallas iButton™ to PRESCO™ for PDA, KC2 or KC6

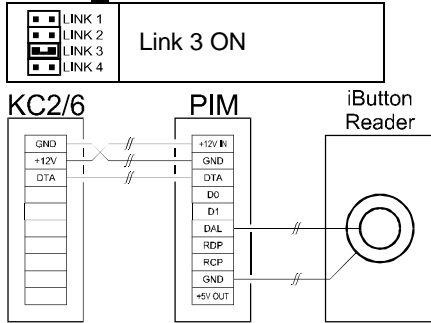

12

The PIM reads the number of bits specified and converts them to a decimal number. The lowest 7 digits of this number are sent as the code.

Dallas iButton™ to RS232

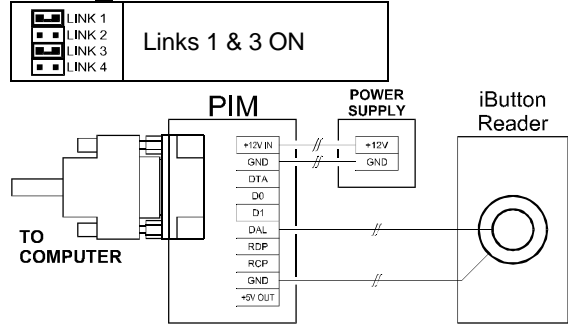

The data can be sent to the RS232 port as either raw binary data, ASCII encoded decimal or ASCII encoded Hexadecimal.

Factory default send format = ASCII encoded Hex (Memory 064)

Converting from Wiegand

The PIM can read up to 64 bits of Wiegand data with or without start and/or end parity bits. It also allows for a site code of up to 32 bits.

Factory defaulted to read 26 bit Wiegand

Factory default Site Code Bits = 8 (Memory 024)

Factory default User Code Bits = 16 (Memory 025)

Factory default Start Parity Bits = 12 (Memory 026)

Factory default End Parity Bits = 12 (Memory 027)

Factory default Start Parity Polarity = Even (Memory 028)

Factory default End Parity Polarity = Odd (Memory 029)

Factory default Check Received Parity = Check (Memory 031)

13

Wiegand to PRESCO™ for PDA, KC2 or KC6

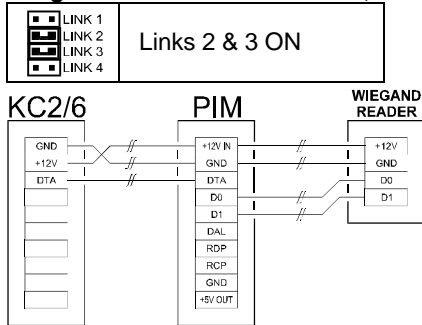

The PIM creates a 7 digit number from the Wiegand data. It converts the site code to a decimal number and takes the lowest 2 digit then it converts the user code to a decimal number and takes the lowest 5 digits.

Wiegand to PRESCO™ for PAC1 or PAC2

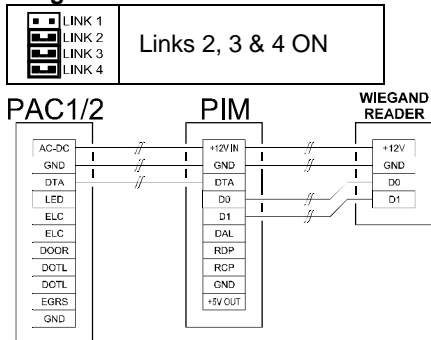

The PIM creates an 8 digit number from the Wiegand data. It converts the site code to a decimal number and takes the lowest 3 digit then it converts the user code to a decimal number and takes the lowest 5 digits.

14

Wiegand to RS232

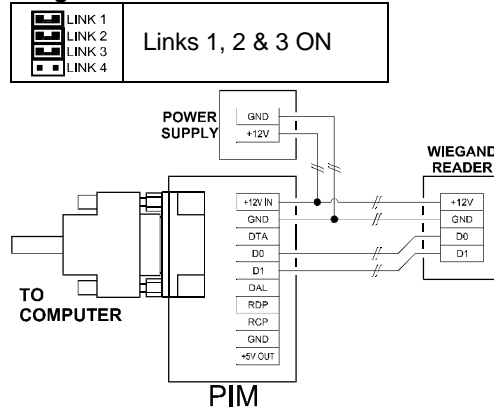

The data can be sent to the RS232 port as either raw binary data, ASCII encoded decimal or ASCII encoded Hexadecimal. The site and user codes are converted and sent as separate numbers, site code is sent first.

Factory default send format = ASCII encoded Decimal (Memory 030)

15

Converting from RS232

All information is sent unfiltered to and from the RS232 port.

NOTE: It is not recommended that these modes be used unless you have full details about the information sent to and from the DTA or DLOG lines. This information is only supplied upon request to those with a reasonable usage.

RS232 to Presco™

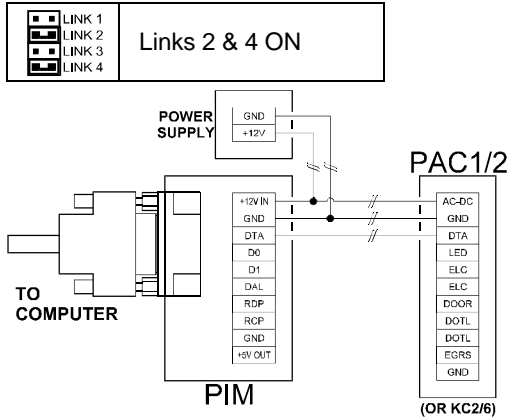

This mode is used to emulate a Presco™ encoder when connected to a decoder. All characters must be sent to the attached decoder, this includes preamble, code and enter characters.

RS232 to Presco™ DLOG



Connect to DT1, 2, 3 or 4 port on a PACDL and use to emulate a Presco™ PAC1 or PAC2 decoder.

16

WIEGAND SETTINGS MEMORIES

- 020 Site code byte 0 (bits 24 to 31): 0 to 255 [0].
- 021 Site code byte 1 (bits 16 to 23): 0 to 255 [0].
- 022 Site code byte 2 (bits 8 to 15): 0 to 255 [0].
- 023 Site code byte 3 (bits 0 to 7): 0 to 255 [1] (used for standard 8 bit site code).
- 024 Number of bits in site code: 0 to 32 [8].
- 025 Number of bits in user code: 8 to 64 [16].
- 026 Number of bits for start parity (0 = no start parity bit) [12].
- 027 Number of bits for end parity (0 = no end parity bit) [12], this is usually site code bits + user code bits – start parity bits.
- 028 Start parity polarity: 0 = Even, 1 = Odd.
- 029 End parity polarity: 0 = Even, 1 = Odd.
- 030 RS232 conversion format: 0 = Binary, 1 = Decimal, 2 = Hexadecimal.
- 031 Check received parity: 0 = Do not check, 1 = Check (new memory for revision B).

CLOCK/DATA SETTINGS MEMORIES

- 040 Number of characters to read: 1 to 32 [8].
- 041 Data type: 0 = Track 1, 1 = Track 2/Track 3.
- 042 Read from start or end: 0 = Read from start, 1 = Read from end (new memory for revision B).

18

PROGRAMMING

Several options are available through the use of memories, these include RS232 port settings, Wiegand data and site code settings and others.

Default values are shown in *italics* where a list is given and in square brackets [] plus *italics* for other settings.

Programming of all memories can be done via a Presco™ PRE keypad connected to the DTA terminal or through the RS232 port.

NOTE that if you program a memory with a value outside those specified for it, or you program an unlisted memory, the functionality of the PIM cannot be guaranteed.

RS232 SETTINGS MEMORIES

- 000 Baud rate: 0 = 300, 1 = 600, 2 = 1200, 3 = 2400, 4 = 4800, 5 = 9600, 6 = 19200, 7 = 38400.
- 001 Parity: 0 = Even, 1 = Odd, 2 = None.
- 002 Handshaking: 0 = None, 1 = Hardware (RTS/CTS).
- 003 Send data config: 0 = code only, 1 = code + start char, 2 = code + end char, 3 = code + start & end chars, 4 = code + start, separator & end chars.
If unfiltered data from Presco™ or binary data from Wiegand or iButton™ is being sent, code only mode (0) is always used no matter what is set for this memory.
- 004 Start data character: Used to indicate the start of a data sequence [2 = STX].
- 005 End data character: Used to indicate the end of a data sequence [3 = ETX].
- 006 Separator character: Used to indicate the end of the site code and start of user code for Wiegand conversion [23 = ETB].

17

iButton™ SETTINGS MEMORIES

- 060 Data bits to read: 0 = Factory ID, 1 = User memory (LSB stored first).
- 061 Number of bits to read: 8 to 64 [32].
- 062 Memory read address high byte: 0 to 255 [default = 0].
- 063 Memory read address low byte: 0 to 255 [default = 0].
- 064 RS232 conversion format: 0 = Binary, 1 = Decimal, 2 = Hexadecimal.
- 065 Presco™ conversion format: 0 = Decimal, 1 = Base 12.

PRESCO™ SETTINGS MEMORIES

- 080 To RS232 filter: 0 = No filtering, 1 = Filter off preamble & enter characters, 2 = Filter + automatically send a good response char.
- 081 Good response character [69 = 1 beep].
- 082 Bad response character [66 = blarp (long beep)].

Valid response characters are:

65 = 2 beeps, 66 = blarp, 67 = 5 beeps, 68 = silence, 69 = 1 beep, 70 = warble, 71 = 3x2 blips, 73 = 3 beeps, 74 = 4 beeps, 75 = 2 blips, 76 = 2x2 blips, 77 = ramp up, 78 = ramp down.

- 083 Wiegand conversion mode: 0 = standard, 1 = Wiegand extender mode.

The Wiegand extender mode uses 2 PIMs between the Wiegand reader and controller to allow for separation distances of up to 1km. The PIM closest to the reader converts the Wiegand data to a special Presco™ format and the second PIM converts it back to the original Wiegand.

19

PROGRAMMING USING A PRESCO™ PRE KEYPAD

1. Connect the PRE white wire to DTA and black wire to GND.
2. Ensure that LINK 1 is **ON**.
3. Press the Program button on the PIM. When the RED LED above the Program button lights, the PIM is in program mode.
4. Press **[*]** <3 digit memory number> <memory value> **[E]**.
5. Repeat step 3 for each memory to be programmed.
6. Ensure links are set for required function.
7. Press the Program button again. When the RED LED goes off all the new values are saved to memory.

PROGRAMMING USING THE RS232 PORT & PC

1. Ensure that LINK 1 is **OFF**.
2. Connect a straight through male to female DB9 cable from the PIM to PC's COM port. The cable only requires the wires for RX, TX and GND, pins 2, 3 & 5.
3. Run the PIM programming software on the PC.
4. Select the COM port the PIM is attached to.
5. Press the Program button on the PIM so that the RED LED above the button is lit.
6. Use the software to set or change the memory values.
7. Ensure links are set for required function.
8. Press the Program button again. When the RED LED goes off all the new values are saved to memory.
9. Exit the software.
10. Disconnect the serial cable, if no longer required.

The software for RS232 programming is available for 'ClubWeb' members from Nidac's website www.nidac.com or by emailing a request to pim.software@nidac.com.

20

PACDL Data logger to record events with time & date stamping from up to 4 PAC1 or PAC2 decoders.

PIM-IBP Special PIM set up as a programmer for Dallas iButton™ memories, includes software. PC, iButton™ receptacle and serial cable are required.

PRS232 Presco™ to RS232 interface with 2 inputs and 1 relay output. Can be used as door control interface for PC or RS232 controller.

CAB-SERIAL 1.8m serial cable to connect PIM to PC.

CS-KEYRDR Dallas iButton™ receptacle in metal plate with LED.

CS-KEYRDR-PR Dallas iButton™ receptacle.

PAC1/2 Programming Software

Presco™ decoder programming software is also available to use with the PIM. This software will allow you to connect a PAC1 or PAC2 to a PIM that is connected to a PC and program all settings and users codes. It also allows the extraction of settings and user codes from existing programmed decoders.

The decoder programming software is available for 'ClubWeb' members from Nidac's website www.nidac.com or by emailing a request to pim.decoder.software@nidac.com.

PIM Programming Software

The software for RS232 programming is available for 'ClubWeb' members from Nidac's website www.nidac.com or by emailing a request to pim.software@nidac.com.

22

OTHER MODELS AND ACCESSORIES

- PRE** Indoor keypad encoder for Presco™ decoder with 2 LEDs and buzzer.
- PSE-NI** Indoor/outdoor, metal, vandal and weather resistant keypad encoder for any Presco™ decoder.
- PSE-IL** Back lit, indoor/outdoor, metal, vandal and weather resistant keypad encoder for any Presco™ decoder. 12 and 24 Volt DC backlighting inputs.
- PRX** Indoor proximity reader with Presco™ and Wiegand outputs, LED and buzzer.
- SPRITE** Indoor/outdoor proximity reader with Presco™ and Wiegand outputs, LED and buzzer.
- PAC1** Door Access Controller, 400 programmable user codes, 5 Amp. 30 Volt Electric Latch Control relay, 1 Amp. 30 Volt alarm relay, 12 to 24 Volt D.C. or 16 to 24 Volt A.C. operation.
- PAC2** 2 Door Access Controller, 400 programmable user codes, 2 x 5 Amp. 30 Volt Electric Latch Control relays, 2 x 1 Amp. 30 Volt alarm relays, 12 to 24 Volt D.C. or 16 to 24 Volt A.C. operation.
- KC1** 1 output decoder for general switching control. 125 programmable user codes, 1 Amp. 30 Volt, NO/NC relay output, 12 Volt D.C. operation.
- KC2** 2 output decoder for general switching control. 125 programmable user codes, 2 x 1 Amp. 30 Volt, NO/NC relay outputs, 12 Volt D.C. operation.
- KC6** 6 output decoder for general switching control. 125 programmable user codes, 6 x Open Collector (logic) outputs, 12 Volt D.C. operation.

21

WARRANTY

NIDAC SECURITY PTY. LTD. will repair or replace this product if proven to be faulty (excluding accidental or malicious damage) under the 36 month warranty offered from the date of purchase.

As NIDAC SECURITY PTY. LTD. or it's agents do not perform the final installation, inspection or training in the use of this product, they cannot be held liable for injury, loss or damage directly or consequentially arising from the use or misuse of this product.

Presco™ is a Trade Mark belonging to NIDAC SECURITY PTY. LTD. The Presco™ Keypad system is protected by patents granted in various countries including Australia.

The software design is protected internationally and remains the intellectual property of NIDAC SECURITY PTY. LTD.

Design improvement and specification are subject to change without notice. All designs are copyright NIDAC SECURITY PTY. LTD. 1992 to 2004.



Designed and Manufactured by:

NIDAC SECURITY PTY. LTD.

2 CROMWELL STREET

BURWOOD, VICTORIA

AUSTRALIA 3125

www.nidac.com

Tel: +61 3 9808 6244

Fax: +61 3 9808 9335