

Electrical

243mA at 12vdc - 187mA at 24vdc
Solenoids are rated for continuous use.

Monitoring

None

Mechanical

Static tested to 1,000 kgs (2,200 lbs) holding force

Warranty

Protected by **TRIGARE** 5 year warranty

Environmental

Operational temperature range -20° to + 60°

Shipping

Product weight = 190 gms
Product weight with box = 235 gms
Shipping size of box = 110 x 70 x 40 mm

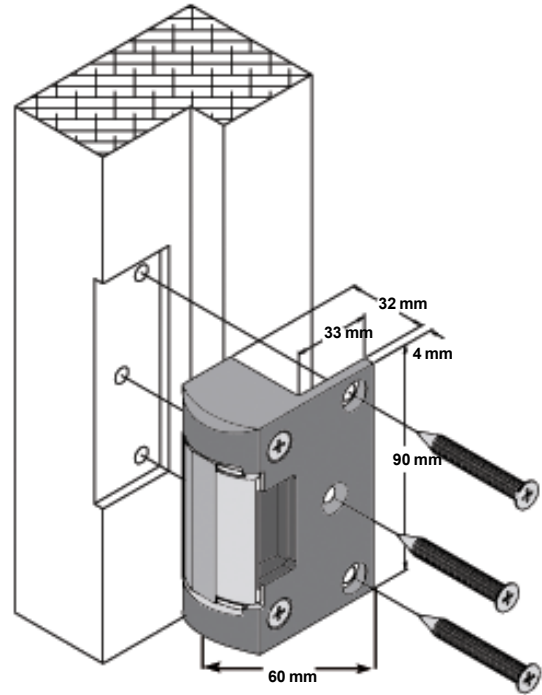

Patented Innovation - as easy as this

Power to open Power to lock



Fail-Secure



Fail-Safe

Power To Open:

When power is supplied to the strike, the unit is unlocked. If power fails, the strike is locked and the door is secured.

Power To Lock:

When power is supplied to the strike, the unit is locked. If power fails, the strike is unlocked, and the door is safe (unlocked) for exit.

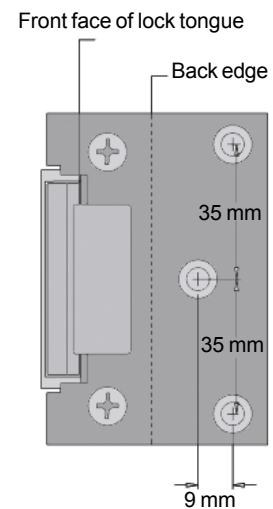

Specification Statement

The electric strike should be a type suitable for use with rim or surface door locks being unaffected by building vibration and offering a 5 year warranty. Where "power to lock" and "power to open" are required, the one lock should be able to achieve either configuration by changing on site. The strike should not consume current greater than 243mA at 12vdc and have a solenoid rated for continuous use.

Distributed by



Padde reserve the right to update Technical Data without notice



Compliant



www.padde.com.au