

Electrical

175 mA at 12vdc - 88 mA at 24vdc
Solenoids are rated for continuous use

Monitoring

Lock = 3 amp changeover
Door / Latch = 3 amp changeover

Mechanical

Exceeds UL1034 and AS4145.2 specifications
Cycle tested to 1,000,000 operations

Warranty

Protected by **TRICARE** 5 year warranty

Environment

Operational temperature range - 20C to +60C

Shipping

Product weight = 487 gms
Shipping weight with box = 508 gms
Shipping size with box = 195 x 48 x 34 mm

Patented Innovation - as easy as this

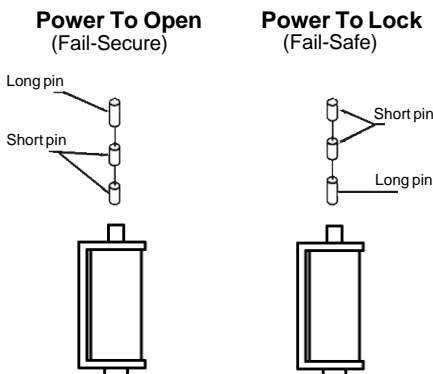

Power To Open:

When power is supplied to the strike, the unit is unlocked. If power fails, the strike is locked and the door is secured.

Power To Lock:

When power is supplied to the strike, the unit is locked. If power fails, the strike is unlocked, and the door is unlocked for exit.

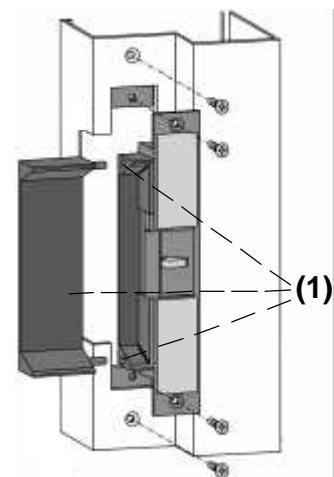
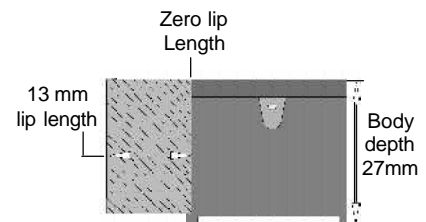
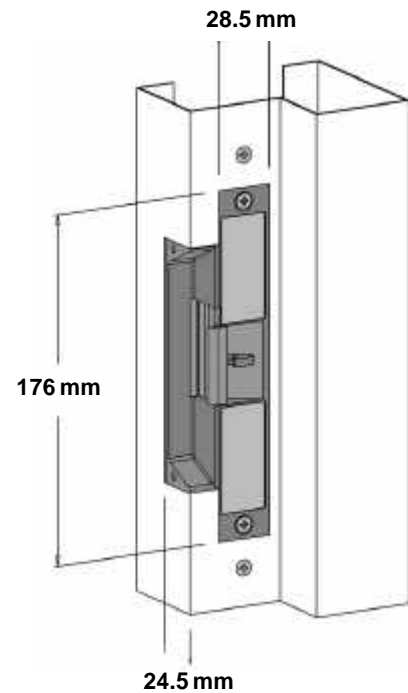

(1) If you order an ES2000X which has pre-drilled extension holes, 25 and 50mm extension lips can be fitted for extra wide door frames.

Specification Statement

The electric strike should be fully monitored using no less than 3 amp contacts and have separate door / latch and solenoid monitor switches. The product should be constructed using solid stainless steel components and provide a minimum 5 year warranty. Where Power to Lock and Power to Open functions may be required in the same building, a single electric strike should be interchangeable from either "power to lock" or "power to open" on site. The electric strike should not consume current greater than 190 mA at 12 volts and have a solenoid suitable for continuous use. A maximum projection of 27 mm for the strike into any door frame is required. A fire rating not less than 4 hours is required where applicable.

Distributed By:



www.padde.com.au