

ES300 / ES3000 technical data

Padde reserves the right to update technical data without notice
VRT - 17.5.05

Electrical

175mA at 12vdc - 88mA at 24vdc
Solenoids are rated for continuous use.

Monitoring

Solenoid Monitor = 3 amp NO / NC microswitch
Door / Latch = 3 amp NO / NC microswitch

Mechanical

Suitable for 18 mm latch tongue with 3 mm door gap
Static tested to 1,363 kg (2998 lbs) holding force

Warranty

Protected by **TRICARE** 5 year warranty

Environment

Operational temperature range -20° to +60°

Shipping

Product weight	= 487 grams
Shipping weight with box	= 640 grams
Shipping size with box	= 220 x 50 x 35 mm

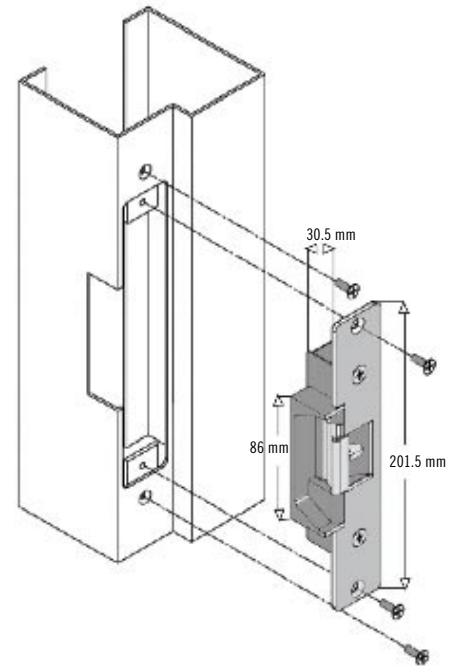

ES3100 ANSI Lip

Specification Statement

The electric strike should be fully monitored using no less than 3 amp contacts and have separate door / latch and solenoid monitor switches. The product should be constructed using solid stainless steel components and provide a minimum 5 year warranty. Where Power to Lock and Power to Open functions may be required in the same building, a single electric strike should be interchangeable from either "power to lock" or "power to open" on site. The electric strike should not consume current greater than 180mA at 12 volts and have a solenoid suitable for continuous use.

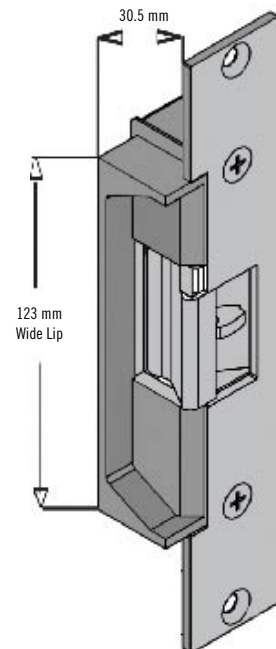

ES3200 Wide Lip

Distributed By:



superior quality, design and innovation

WWW.PADDE.COM.AU