



Buck Boost Converter

Have you ever installed a long cable run and found the voltage at the far end was too low to power the device? Or have you needed to power a 12V device and the only available power was 24V?

Developed to provide a regulated 11V-16V DC output (adjustable), where input voltage ranges from 10V to 36VDC, the TPS-BB-13 Buck Boost Converter is the answer.

If input voltage is either too high or too low at your equipment, the TPS-BB13 can automatically boost (increase) or buck (decrease) voltage to meet the device's requirements.

There is no effect on the output during the transition from buck to boost (or vice-versa). This module also features an on-board battery charging facility when the output is adjusted to 13.8V DC.



Additional Features

- Output over current and short-circuit protection
- Internal Thermal shutdown
- Replaceable output fuse
- Reverse Battery protection
- On-board 150 mA current limited battery charger if output is adjusted to 13.8V (Ensure that your equipment is suitable for 13.8V DC operation)

Specifications:

Input Voltage Range :	9.5 - 36V DC
Output Voltage :	12.1V DC (11-16V DC adjustable)
Maximum Output Current :	1 Amp
Load Regulation :	< 1% from 0% to 100% load
Line Regulation :	< 0.2%
Soft Start :	Typically 1-2 seconds
Output Ripple & Noise :	< 20 mV at full load over full input range
EMC :	CISPR 11 Class B
Dimensions :	114 mm x 91 mm x 38 mm

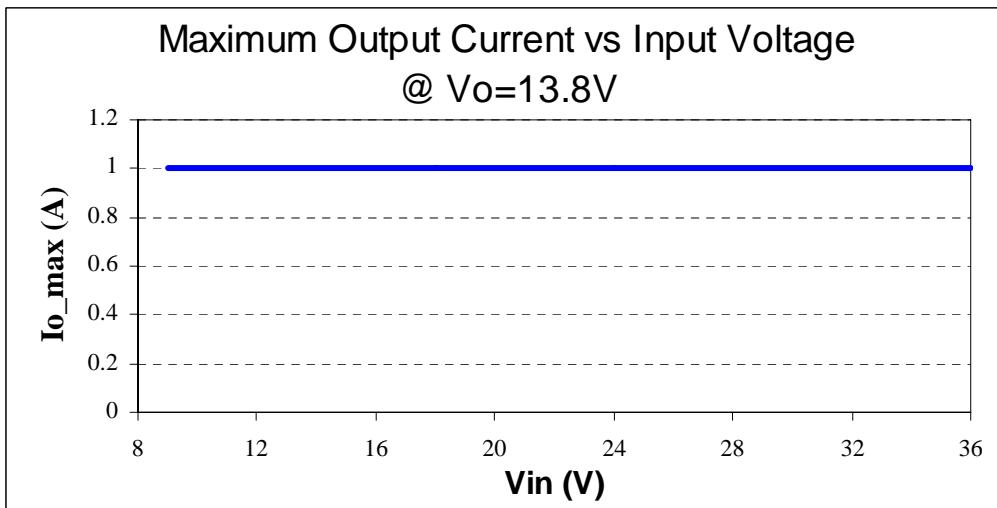

Tactical Technologies Pty Ltd, 5 Butterfield St, Blacktown NSW 2148
 Ph: (61-2) 8822-1888 Fax: (61-2) 8822-1899
 sales@tac-tech.com.au www.tac-tech.com.au

TPS-BB-13

Typical Installation Example

Scenario

- Eight 12V cameras are powered by a centrally installed 12V DC 5 Amp power supply.
- At the end of a 250 metre cable run to one of the cameras, voltage under load is only 9.8V DC - not enough to power the camera.

Solution

- Tactical Technologies TPS-BB-13 Buck Boost Converter.

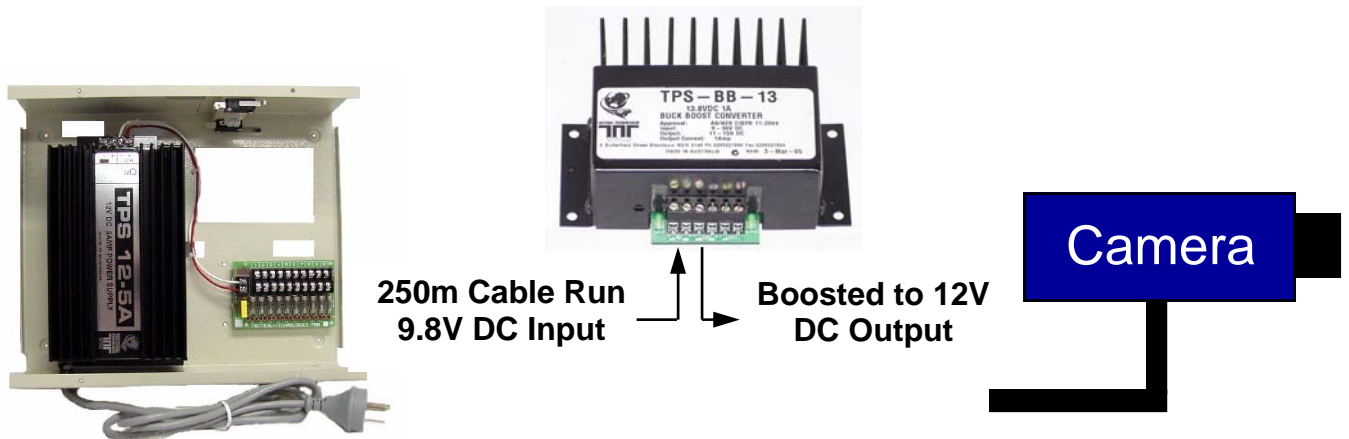

Wiring Diagram

